



Zerc Installation Instructions

PYI Inc. takes no responsibility for damage inflicted to the Max-Prop while using these instructions as a guide for the installation of the plugs or zerc fittings. These instructions are merely a guide that furnish a sequence of steps and locations.

Parts included:

- 13/64" drill bit (1 ea)
- 6mm x 1mm tap (1 ea)
- 6mm x 1mm zerc plug set screws 8mm length (2ea)
- 6mm x 1mm thread zerc tower (1ea)
- 3mm allen wrench (ea)

The holes are to be drilled into the half of the spinner that does not have the stop. See part (#7A in figure #1).

1. The pitch setting on the Max-Prop is adjustable, so make sure that the pitch is known before the Max-Prop is taken apart.
2. Disassemble the Max-Prop and remove the two spinner halves.
3. Set the proper half of the spinner (part #7a in figure #1) in the vice of a drill press. Level it so that the internal bearing surfaces are facing upward. Secure the half so that it will not move when being drilled.
4. With the 13/64" drill bit, drill through the two bearing surfaces marked " * " in figure #2.
5. De-burr the two holes drilled.
6. Turn the half over and re-secure it in the vice exposing the outside of the spinner.
7. With the 6mm x 1mm tap held parallel to the holes just drilled, turn the tap 5½ turns. Remove the tap and clean the shavings out of the hole.
8. Insert and tighten one set screw per hole making sure that the set screw is either flush or slightly inset.
9. If either set screw rises above the outer surface, remove the set screw, reinsert the tap, cut one complete new thread, remove the tap, and reinsert the set screw making sure that it is flush.

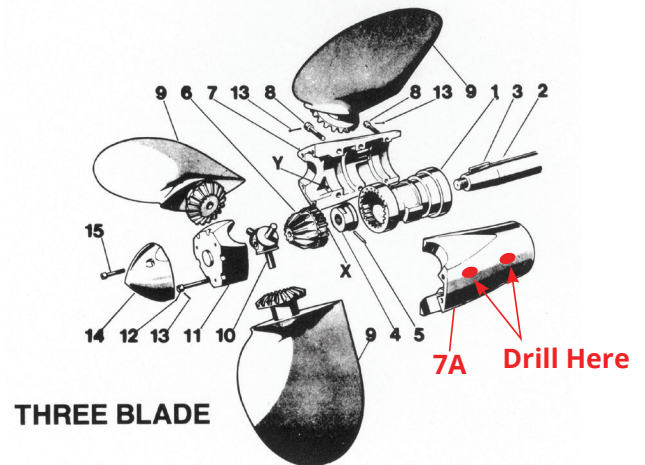
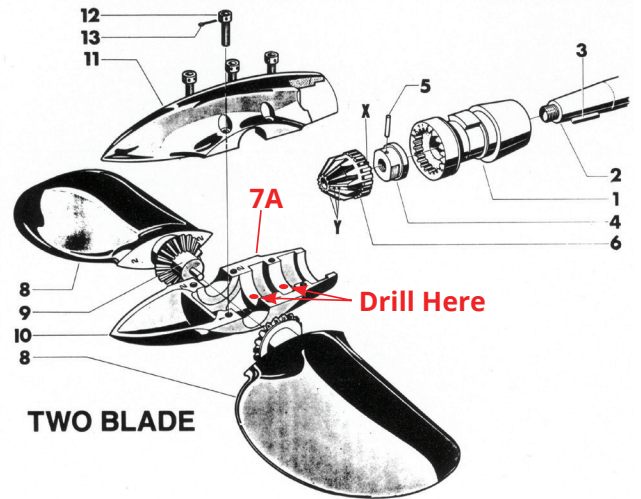

Figure 1.

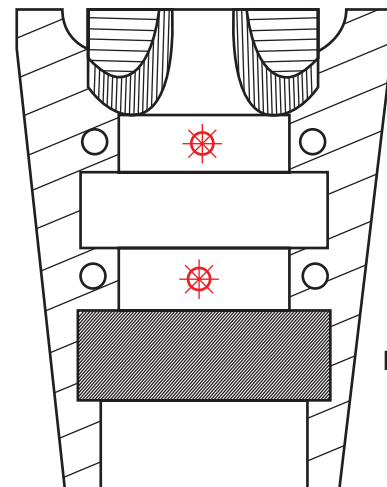

Figure 2.